

BEYOND



CPAPMAN.COM
BEST SERVICE SINCE 1997

CE 0197

**BEYOND ResPlus C-20A CPAP
User Manual**

Please read this manual carefully before using this product

User Manual

The following document is the User Manual for the BEYOND ResPlus C-20A CPAP (“C-20A CPAP” or “the device”) manufactured by Hunan Beyond Medical Technology Co., Ltd. (hereafter, called “BEYOND Medical”).

All the information contained in this document is the legal property of BEYOND Medical and, unless specifically authorized in advanced and in writing by BEYOND Medical, the material contained in this document must not be reproduced in any means. Without a written authorization from BEYOND Medical, no institutions, companies, or individuals have the right to produce, sell, duplicate, or imitate the products contained herein. Doing so constitutes an infringement of the scope of our patent protections and constitutes a violation of the U.S. law.

BEYOND Medical reserves the right to pursue legal remedies against all such violations.

Contents

| | |
|--|----|
| 1. Introduction..... | 1 |
| 1.1 Intended use | 1 |
| 1.2 Warnings..... | 1 |
| 1.3 Cautions | 2 |
| 1.4 Contraindications | 3 |
| 2. Model..... | 4 |
| 3. Package Contents | 4 |
| 4. Device Components | 4 |
| 5. Device Symbols | 5 |
| 6. Device Operation | 6 |
| 6.1 First Use..... | 6 |
| 6.2 Daily Use | 6 |
| 7. Humidifier..... | 7 |
| 7.1 Humidifier Composition | 7 |
| 7.2 Humidifier Connection & Separation with the Host Unit..... | 8 |
| 8. Using the SpO2 Kit..... | 9 |
| 9. Parameter settings | 10 |
| 9.1 Main Interface Screens | 10 |
| 9.2 PFCurve interface | 11 |
| 9.3 Parameter Setting Interface..... | 11 |
| 9.4 System Setting Interface | 13 |
| 9.5 Information Setting Interface..... | 15 |
| 9.6 Epworth Interface | 16 |
| 10. Prompt..... | 18 |
| 11. Cleaning, Disinfection and Maintenances..... | 18 |
| 11.1 Timing between Cleanings | 18 |
| 11.2 Cleaning | 19 |
| 11.3 Disinfection..... | 19 |
| 11.4 Transferring to Another User..... | 19 |
| 12. Troubleshooting | 20 |
| 13. Specifications | 22 |
| 14. Traveling with the Device..... | 24 |
| 15. Service | 25 |
| 16. Technical Support | 25 |
| 17. Disposal | 25 |
| 18. Warranty | 25 |
| 19. EMC Requirements..... | 26 |
| Manufacturer:..... | 29 |
| U.S Agent: | 30 |

1. Introduction

1.1 Intended use

The BEYOND ResPlus C-20A CPAP is designed for delivery of positive airway pressure to provide non-invasive ventilation for adult patients with respiratory insufficiency or obstructive sleep apnea (OSA) in home or hospital environment. Rx only: Federal law restricts this device to sale by or on the order of a licensed healthcare practitioner.

Please consult with a licensed health care professional prior to using this device. BEYOND Medical manufactures several accessories that are available to make your OSA treatment with this device as convenient and comfortable as possible. To ensure that you receive the safe and effective therapy, only use accessories manufactured by BEYOND Medical with this device.

1.2 Warnings

These warnings are meant to caution the user or operator of this device that there is a substantial risk of injury if these warnings are not followed.

⚠ These instructions are for reference only. They cannot replace the expert medical guidance from a licensed healthcare professional for the proper use of this device.

⚠ This device is not intended to be used to provide life support.

⚠ The proper operation of this device may be influenced or disturbed if any of the following conditions exist nearby:

- Electromagnetic fields exceeding 3V/m under the EN60601-1-2 test conditions.
- The operation of a high frequency device (diathermy).
- Electric shocks from a defibrillator or a short-wave therapeutic device.
- Radiation (such as, x-ray or CT).
- Electromagnetic field (such as, MRI).

⚠ Use only BEYOND Medical circuit accessories.

⚠ Do not wear the mask for longer than a few minutes while the device is not in operation.

⚠ Keep the device dry, ensure the tubing isn't tangled.

⚠ If you notice any damage to the device or experience any unusual performance (such as, harsh sounds or unfamiliar odors), quickly disconnect the power supply, empty the water tank, and stop using the device. Once the device is turned off, contact your BEYOND representative or local distributor.

⚠ The C-20A CPAP, like all CPAP devices, has a potential to allow users to rebreathe their own exhaled air. To reduce the chance of this possibility occurring, please observe the following precautions:

- Only use BEYOND Medical circuit accessories.
- Do not wear the mask for longer than a few minutes while the device is not in operation.
- Do not block or seal the vent holes in the exhalation port.

⚠ This device is not recommended to be used in combination with oxygen therapy. Sources of medical oxygen must be located more than 1 meter from this device to avoid the risk of fire.

⚠ Do not operate this device in the presence of flammable anesthetic mixtures, especially in combination with oxygen.

- ⚠ Do not operate this device in the presence of nitrous oxide and oxygen.
- ⚠ Keep away from toxic or hazardous steam.
- ⚠ Do not use this device if the room temperature is higher than 35°C (95°F). If the ambient temperature of the room is higher than 35°C (95°F), the air flow from the device may rise to exceed 40°C (105°F), which may cause damage to the user's airway.
- ⚠ Do not use this device in direct sunlight or near heating equipment. Doing so may increase the air temperature of the output to unsafe levels.
- ⚠ To avoid electrical shock, disconnect the power cord before cleaning. Do not immerse the device in fluid of any kind.
- ⚠ Contact your healthcare provider if symptoms of sleep apnea recur.
- ⚠ Regularly check the power cable and accessories for any damage or wear.
- ⚠ Disconnect the power supply before checking the device.
- ⚠ When using this device, make sure the mask is positioned above the height of the host unit. Failure to do so may cause any condensed water in the tubing to flow into the user's nose, creating the risk of possible suffocation.
- ⚠ Stop using this device if the humidifier is damaged.
- ⚠ Do not touch the heater plate after turning the device off. Let the heater plate cool off before touching. The plate will remain hot for several minutes after the power supply has been disconnected.
- ⚠ Do not add water hotter than 35°C (95°F).
- ⚠ Do not splash any water into the device when refilling the water tank.
- ⚠ Be sure that the device is in a place that cannot be accessed or touched by children, who could be entangled, injured, or strangled by the tube.
- ⚠ Appliance coupler is used as isolation means for the device, please do not position the device so that it is difficult to operate the coupler.
- ⚠ Do not attempt to modify this device without written authorization from the manufacture.
- ⚠ Do not place the device next to any curtains or similar obstruction. Curtains can block the airflow to the device, which may cause this device to overheat.
- ⚠ Do not block the air Intake Port. Doing so will interfere with the therapy.
- ⚠ The proper placement and positioning of the mask on the face is critical to the consistent operation of this device.
- ⚠ The local distributor of this device is available to provide technical support.
- ⚠ Do not perform any maintenance on the device while user is receiving the treatment.
- ⚠ All materials that come in contact with the human body have been tested for biocompatibility and meet the requirements of biological compatibility
- ⚠ Approved adapters are specified as part of the device.

1.3 Cautions

The following precautionary statements indicate conditions or actions that might damage the device or injure the user. Please read this section carefully.

- ⚠ Do not begin wearing the mask until the device has started to run normally.
- ⚠ Do not operate the device if the ambient temperature is outside of the operating temperature range (listed under Section 13). If the device has been exposed to temperatures that are above the operating temperature range, return the device to room temperature before use.

- △ Do not immerse the device in liquid of any kind. Do not let any liquid enter into the device or into the filter near the air inlet.
- △ The condensate water can damage this device. Make sure that the device returns to room temperature before use.
- △ Be sure that the filter is seated properly in the device to ensure normal operation.
- △ Any tar from smoking cigarettes near the device will stop the device from working properly.
- △ If any liquid splashes onto the heater plate, disconnect the power supply and do not use it until the plate is completely dried.
- △ Take all possible preventive measures to avoid water damage to the device.
- △ Only use distilled water in the water tank. If any other type of liquid is put in the water tank, it may damage the humidifier and/or device, possibly endangering the health of the user.
- △ Do not exceed the maximum water level mark on the water tank.
- △ Do not splash the water into the device when filling the water tank.
- △ Do not tilt the device. Keep the device level in order to avoid water flowing back into the device. If water does get inside the device, disconnect the power immediately and stop using it.

1.4 Contraindications

If the user has severe respiratory failure without spontaneous breathing, do not use the device. If any of the following conditions apply, consult the healthcare provider before using the device.

△ Absolute contraindications:

Pneumothorax or mediastinal emphysema; cerebrospinal fluid leak, traumatic brain injury, or pneumocephalus; shock caused by a variety of conditions before treatment; active epistaxis; upper gastrointestinal bleeding before treatment; coma or impaired consciousness that makes using the mask during therapy impossible; or giant vocal fold polyp, etc.

△ Relative contraindications:

Severe coronary heart disease complicated with left ventricular failure, acute otitis media, excessive respiratory secretions and weak cough, weak spontaneous breathing, nasal or oral tracheal intubation and tracheotomy, severe nasal congestion caused by a variety of conditions, lung bullae, and allergies to the breathing masks, etc.

△ The following side effects may occur during treatment:

- Dryness of the mouth, nose and throat
- Abdominal bloating
- Ear or sinus discomfort
- Eye irritation
- Skin irritation due to the use of a mask
- Chest discomfort

If you have any symptoms of discomfort, please contact your healthcare provider immediately.

2. Model

| Model | Type | Main components | Working Mode | MaxPressure (cmH2O) |
|-------|-----------|--|--------------|---------------------|
| C-20A | Auto CPAP | Host Humidifier H10 SpO2 Kit S10(optional) | CPAP APAP | 20 |

3. Package Contents

| Item | Articles | Quantity | Remark |
|------|---------------|----------|----------|
| 1 | Host | 1 | Standard |
| 2 | Humidifier | 1 | Standard |
| 3 | Tubing | 1 | Standard |
| 4 | Mask | 1 | Standard |
| 5 | Adapter | 1 | Standard |
| 6 | User Manual | 1 | Standard |
| 7 | Air Filter | 2 | Standard |
| 8 | SpO2 Kit | 1 | Optional |
| 9 | Carrying Case | 1 | Standard |
| 10 | TF Card | 1 | Standard |

4. Device Components

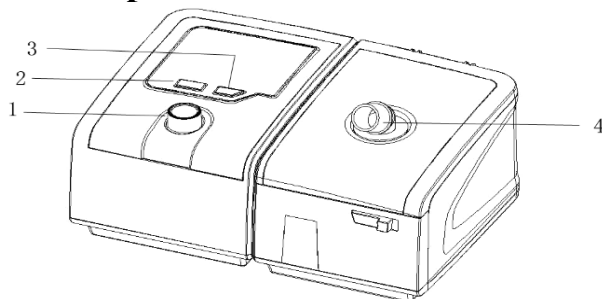

Fig. 4.1

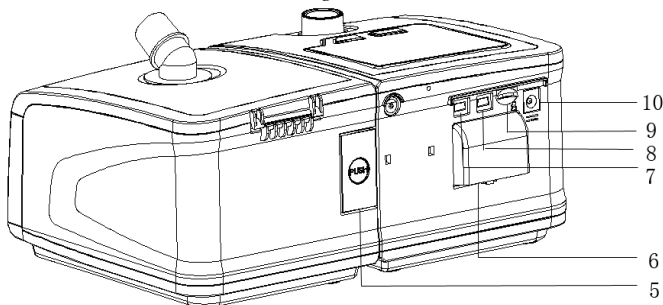

Fig. 4.2









| | | |
|----|------------------------------|---|
| 1 | Dial | Can be rotated in either direction or pressed to select. |
| 2 | Mute | Pressing this button turns off the voice alarm |
| 3 | On/Off Button | Pressing this button switches the device On or Off. |
| 4 | Air Outlet | This is the connection point for the tubing |
| 5 | Humidifier Separation Button | Pressing this button separates the humidifier from the host unit. |
| 6 | Air Inlet | The air filter is placed in this air exchange port. |
| 7 | SpO2 Port | This is the connection point for the SpO2 Kit |
| 8 | Data Port | This is the port for connecting to an external data device. |
| 9 | TF Card port | This is the port where a TF card is inserted. |
| 10 | Power Port | This is where the cord from the adapter is Connected. |

⚠ Do not remove the Dial cap. The metal rod connected to the Dial may come in contact with the external current, creating the risk of an electric shock. If the Dial cap falls off, contact the local distributor to purchase a replacement.

⚠ In case of the failure of any of the buttons, contact the local distributor.

5. Device Symbols

These symbols are provided in the labeling papers to give users safety instructions, please read through their definitions carefully before using.

| Symbol | Definition |
|---|--|
|  | Warnings or Caution |
|  | Type BF applied part |
|  | Serial number of the product |
|  | Date of manufacture |
|  | Follow instructions for use |
|  | The authorized EU-representative |
|  | Manufacturer's Information |
|  | CE Mark |
| IP22 | Degree of Protection Against Ingress of Water and Particulates |
|  | Conforms to the Waste Electrical and Electronic Equipment /the Restriction of the Use of Certain Hazardous Substances in Electrical and Electronic Equipment |

| | |
|---|--|
|  | Heat Warning |
| Rx Only | Caution: Federal law restricts this device to sale by or on the order of a licensed healthcare practitioner. |

6. Device Operation

6.1 First Use

6.1.1 Place the device on a steady flat table where the settings are easy to reach and the information on the display can be clearly seen by the user.

⚠ Maintain at least 2 inches between the device and the wall to ensure that the air inlet is not obstructed.

⚠ When using the device, ensure that the surrounding air flows freely. Keep the device away from any heating and cooling devices (air conditioning vents, radiators, etc)

6.1.2 Place the air filter in the slot at the Air Inlet port.

6.1.3 Connect one end of the tubing into the Air Outlet.

6.1.4 Connect the mask into the other end of the tubing.

6.1.5 Connect the power adapter into the Power Port on the rear of the device.

6.1.6 Connect the device to mains power supply. The device will display the Standby Interface

6.1.7 Connect the power supply. Press the On/Off Button to start the device.

The Connections should appear as shown in *Fig 6.1* below:

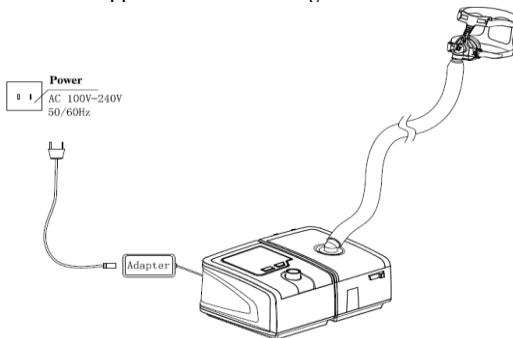

Fig.6.1

⚠ Put the device on a solid flat surface where the approach is not blocked, the displays are easy to see, and the controls are convenient to access. Be sure to place the device where it cannot fall easily. The device needs to be lower than the height of the bed.

⚠ Do not place the device in or on a container where water may gather.

⚠ Be sure to take preventive measures in order to avoid water damage to the device.

⚠ When water is in the humidifier, do not move the device, so as to avoid water entering into the device.

6.2 Daily Use

6.2.1 Assembling the Device

Connect the power supply and the tubing as listed for the first use (see above). Connect the mask and the headgear according to the Mask User Manual (provided separately).

6.2.2 Adjust the Tubing

Adjust the tubing to make sure the tubing can move freely when the user is in a deep sleep. Adjust the mask and the headgear to make the user feel as comfortable as possible and prevent air from blowing into the user's eyes.

6.2.3 Start the Device Running

Press the On/Off Button. The device will begin to run and therapy data (such as, air pressure and temperature) will be shown on the display screen.

6.2.4 Humidifier Heating

If using the humidifier, it is recommended that the unit be used with the tubing which provided by BEYOND Medical to prevent leakage. If the humidifier is attached to the device but the user does not want to use the humidifier, turn the humidifier off.

6.2.5 Ramp Function

When using the Ramp Function, the device will begin at a low initial pressure and increase to the desired pressure setting in a steady rise over the time period selected by the user. After this function is selected, press the On/Off Button once, the device will start to run in accordance with the Ramp Function's settings. If the On/Off Button is pressed a second time, the device will cancel the Ramp Function and run at the selected pressure.

6.2.6 Turn Off the Device

When the mask is taken off, the device will stop running. The user then needs to turn off the device by unplugging the power supply.

7. Humidifier

In drier regions, prolonged use of the device may dry out the user's nasal passages, causing discomfort. This device is equipped with a humidifier to address this issue. When water is added to the humidifier and it is turned on, moisture will be added to the inhaled air to moisten the user's nasal passages.

7.1 Humidifier Composition

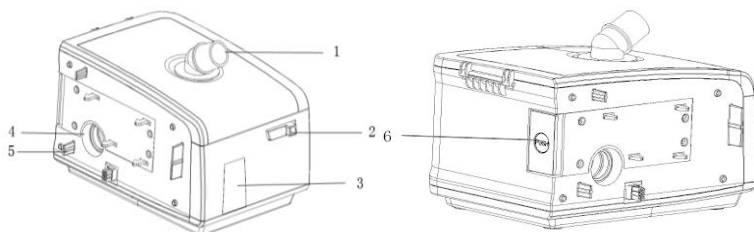

Fig.7.1

| | |
|---|------------|
| 1 | Air Outlet |
|---|------------|

| | |
|---|---------------------------|
| 2 | Humidifier Cap Key |
| 3 | Water Checking Window |
| 4 | Air Inlet |
| 5 | Humidifier Connector |
| 6 | Humidifier Separation Key |

7.2 Humidifier Connection & Separation with the Host Unit

7.2.1 Connect with the host unit

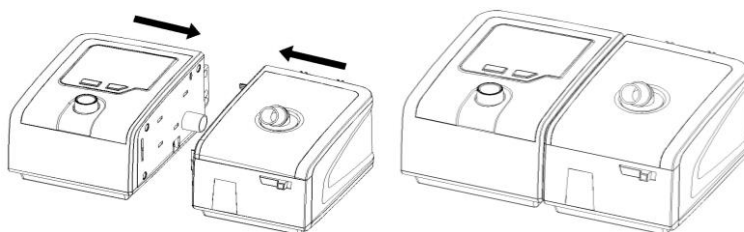

Fig.7.2.1a Before the connection Fig.7.2.1b After the connection

Push the host unit and humidifier together to connect them to each other. A “click” sound will be heard when they are properly connected.

△ Push the humidifier to connect with the host completely.

7.2.2 Separate from the host unit

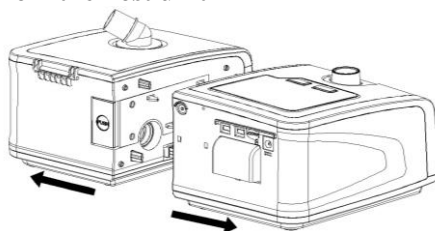
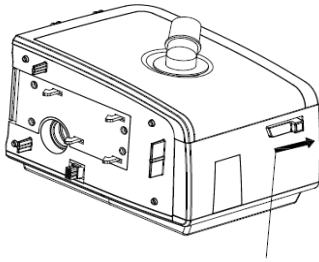

Fig.7.2.2

Press the Humidifier Separation Button while simultaneously pulling the humidifier apart from the host unit.

7.2.3 Adding water into the water tank

(1) Take out the water tank: move the humidifier cover by sliding the Humidifier Cap Key to the right side as shown in *Fig.7.2.3a below*. Then, open the humidifier cover to take out the water tank by grasping the tank with thumb and index finger as pictured in *Fig.7.2.3b*.



Humidifier Cap Key

Fig.7.2.3a

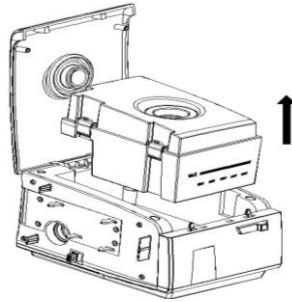

Fig.7.2.3b

(2) Add water through the Air Inlet port on top of the water tank. Make sure the water level does not exceed the Max line.

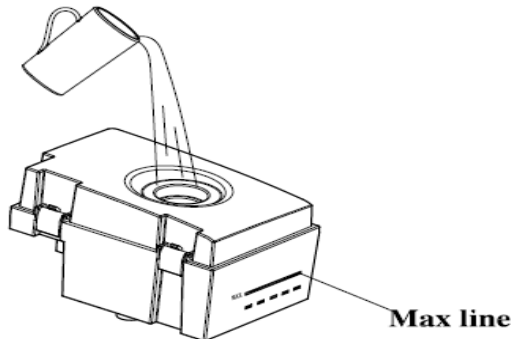

Fig.7.2.3c

- ⚠ In winter months, be sure to add warm water, but no hotter than 35°C (95°F).
- ⚠ Do not fill the water tank above the Max line.
- ⚠ Turn off the humidifier when the water tank is empty. Turn the device off before refilling water. Do not add water when the humidifier is in operation. Only add water when the humidifier has cooled down.
- ⚠ Do not let any water enter the host unit.

8. Using the SpO2 Kit

The SpO2 Kit consists with a SpO2 Probe, Adapter, and Connector. The SpO2 Kit is intended to be used for continuous, non-invasive functional arterial oxygen saturation (SpO2) and pulse rate monitoring for adults weighing more than 40 kg (90 pounds). The SpO2 Kit is immediately ready to use when it is connected to the main device via the Communications Port. Attach the Oxygen Probe sensor to the user's index finger (although other fingers can also be used).

The sampling frequency of the SpO2 signal is 50Hz, and the update frequency of the device is 1Hz. The value of SpO2 is calculated by the average of the previous eight pulse waveforms.

If the SpO2 Kit does not connect or is not performing correctly, the value of SpO2 will not be displayed on the Main Interface.

9. Parameter settings

9.1 Main Interface Screens

Connect the device properly to mains power supply with power cord and power adapter. The screen displays the Main Interface screen will appear as shown in Fig. 9.1 below.

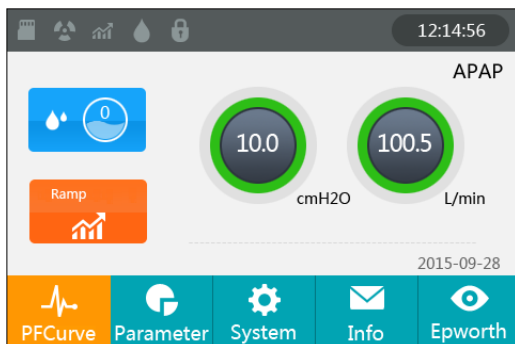







Fig.9.1: C-20A Main Interface

△ Users can set the desired humidifier levels and the Ramp time on the Main Interface; the selectable values ranges are preset on the parameter interface.

△ When the humidifier is not connected to the device, the Humidifier setting icon in the main Interface is grayed and cannot be accessed.

△ SpO2 and Pulse Rate are only displayed when the SpO2 Kit (optional parts) is correctly attached.

| Icon | Meaning |
|---|--|
| 1  | The TF card is inserted. |
| 2  | The device is working. |
| 3  | The Ramp function has been set. |
| 4  | The humidifier level has been set. |
| 5  | Indicates that the parameters setting interface is locked. When the device is connected to the power, its locked by default; Unlock the parameter interface by pressing the Dial button and holding for 5 seconds while the cursor is located on “Parameter” option. After unlocking successfully, the icon will change to  . |

9.2 PFCurve interface

Under main interface, rotate the “Dial” button to move the cursor onto the “PFCurve” indicator and press “Dial” button; the PFCurve Interface screen will appear on the display screen, as shown in *Fig. 9.2* below.

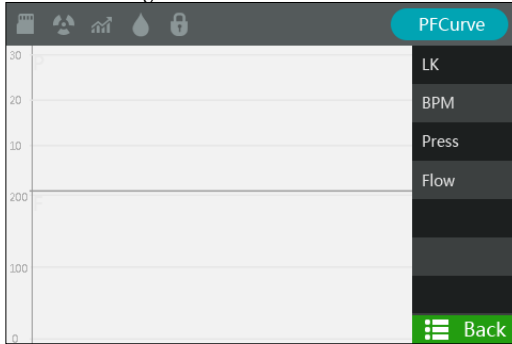

Fig.9.2: C-20A PFCurve Interface Screen

9.3 Parameter Setting Interface

Under the main interface, rotate the "Dial" button to move the cursor onto the “Parameters” icon, and then press the " Dial " button for 5 seconds to unlock. This will bring you to Parameter Setting Interface screen, as shown in *Fig.9-3a* below. Next, press the " Dial " button again and the selected font will turn yellow, indicating that the device’s parameters can now be set, as shown in *Fig. 9-3a* through *Fig. 9.3.c* below.

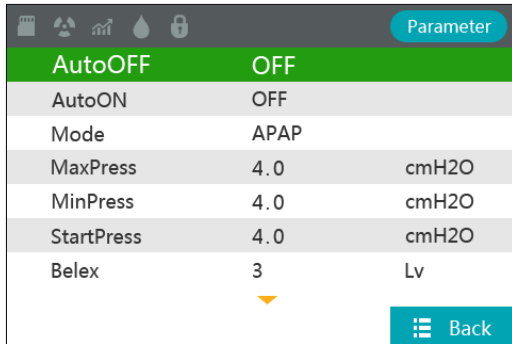

Fig.9.3a : C-20A Parameter Setting Interface Screen 1

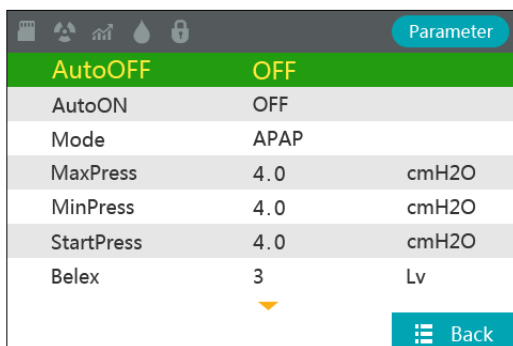

Fig.9.3.b : Selected Status Screen

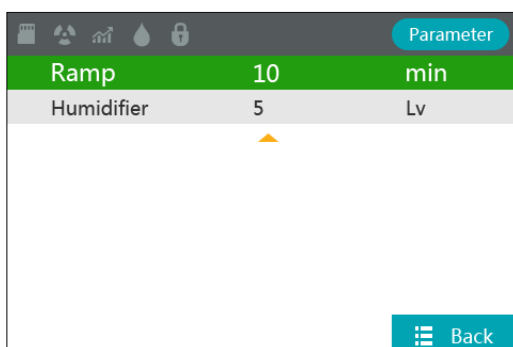

Fig.9.3c : C-20A Parameter Setting Interface Screen 2

| Parameter | Range | Description |
|-----------|------------|--|
| Auto ON | ON/OFF | When the Auto ON is set to “ON”, the user can wear the mask and take 3 breaths in device’s Standby State. The device will then automatically enter into the Working State. |
| Auto OFF | ON/OFF | When the Auto OFF is set to “OFF”, the user needs to remove the mask while the device is in the Working State. Within 15 seconds the device will automatically enter into the Standby State. When this function has been turned ON, the device will automatically enter into the Standby State whenever the user’s mask falls off or the tubing becomes disconnected while the user is asleep. |
| * Mode | APAP/C PAP | The APAP mode allows pressure to be automatically adjusted for improved user comfort based on continual monitoring of apnea and snoring events. The CPAP mode provides a constant level of pressure throughout the breathing cycle. |

| | | |
|-------------|---|---|
| *Press | 4-20 cmH ₂ O | This setting sets the output pressure for the device. It can be set in increments of ± 0.5 cmH ₂ O. |
| *StartPress | 4.0-20.0 cmH ₂ O | <p>CPAP Mode: The initial air pressure for the Ramp Function is equal to or less than the standard air pressure selected by the user.</p> <p>APAP Mode :</p> <ol style="list-style-type: none"> 1. When the initial air pressure is equal to or less than the minimum pressure, it is used as the starting pressure to begin the Ramp Function. 2. When the initial pressure is greater than the minimum pressure, it is used as the output pressure after power is turned ON. <p>This parameter can be set in increments of ± 0.5 cmH₂O.</p> |
| *MinPress | 4.0-20.0 cmH ₂ O | The minimum output pressure parameter can be auto-adjusted at increments of ± 0.5 cmH ₂ O. |
| *MaxPress | 4.0-20.0 cmH ₂ O | The maximum output pressure parameter can be auto-adjusted at increments of ± 0.5 cmH ₂ O. |
| *Belex | 0-3 level | Setting the Belex function while the device is in CPAP Mode will enable the device to detect the respiratory rhythm of the user. This function will lower the pressure in the mask during exhalations to make the user feel more comfortable. |
| Ramp | 0-60 min | This parameter sets the time it takes for the air pressure to ramp up to the final pressure selected by the user (MaxPress) |
| Humidifier | 0 (OFF) to 5 (Maximum) | This parameter sets the output air humidity level for the device. The higher the value, the higher the humidity. "0" indicates that the humidifier is off. The default value before dispatched from the manufacturer is "0". |
| Tips | <i> "*" indicates that this parameter can only be adjusted while the parameter interface is unlocked. To unlock the parameter interface, position the cursor over the "Parameter" icon and then press and hold the Dial Button for 5 seconds to unlock.</i> | |

9.4 System Setting Interface

Rotate the "Dial" button so that the cursor on the Main Interface screen is pointing at "System", then press the "Dial" button to enter into the System Setup Interface screen, as shown in Fig.9.4a .

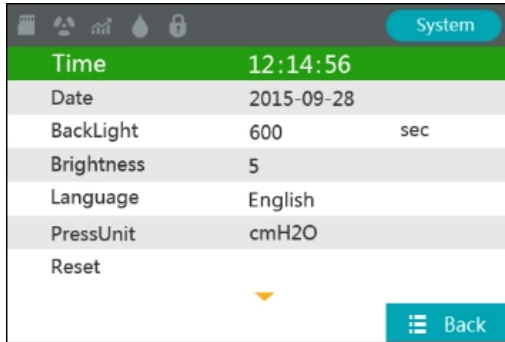

Fig.9.4a : System Setting Interface Screen 1

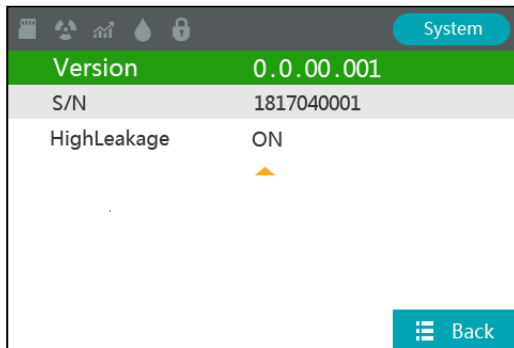

Fig.9.4b : System Setting Interface Screen 2

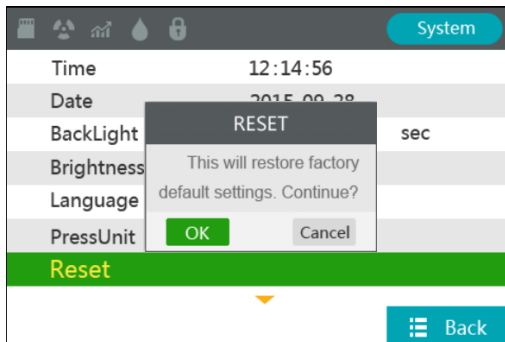
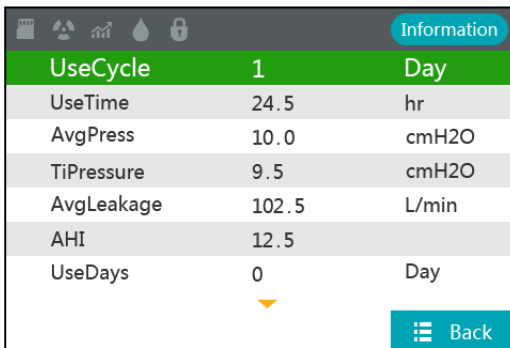

Fig.9.4c: System Setting Interface Screen (with Reset Dialogue Box active)

| Parameter | Setup range | Description |
|-------------|------------------------|--|
| Time | h-m-s | This parameter sets the device's internal clock to track the time. This time will then be used to record the application information for users. This setting needs to be checked frequently to ensure continued accuracy. |
| Date | yyyy-mm-dd | This parameter sets the device's internal calendar to track the date. This date will then be used to record the application information for users. This setting needs to be checked frequently to ensure continued accuracy. |
| BackLight | 30-600 sec | This parameter sets the length of time that the LCD display will be back lit. When the user sets a value, the backlight will turn off after the set time elapses. |
| Brightness | 1-5 level | This parameter has a five-level range. The higher the level, the greater the screen brightness. |
| Language | Chinese-English | Can be switched from English to Chinese. Chinese language User Manuals can be requested from the manufacturer. |
| PressUnit | cmH ₂ O-hPa | Displayed values can be switched between "cmH ₂ O" and "hPa", as desired by the user. |
| Reset | ----- | System Restore will return all system parameters back to the factory default values. |
| HighLeakage | OFF/ON | This parameter sets the high leakage prompt function for the device. |

9.5 Information Setting Interface



| Information | | |
|-------------|-------|--------------------|
| UseCycle | 1 | Day |
| UseTime | 24.5 | hr |
| AvgPress | 10.0 | cmH ₂ O |
| TiPressure | 9.5 | cmH ₂ O |
| AvgLeakage | 102.5 | L/min |
| AHI | 12.5 | |
| UseDays | 0 | Day |
| ▼ | | |
| | | Back |

Fig.9.5a : C-20A Information Setting Interface 1

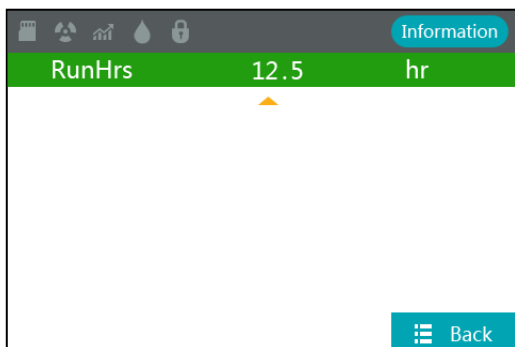

Fig.9.5b : C-20A Information Setting Interface 2

| Parameter | Setup range | Description |
|------------|-------------------|--|
| UseCycle | 1/7/30/90/180/365 | The time period over which the following information items are calculated. Unit is "day". |
| UseTime | ----- | The length of time that the device has been connected to the power supply. Unit is "hour". |
| AvgPress | ----- | The average output pressure value of the device in the running state within the life cycle. Unit is "cmH ₂ O". |
| TiPressure | ----- | The 95% output pressure value of the device in the running state within the life cycle, measured by usage time. Unit is "cmH ₂ O" |
| AvgLeakage | ----- | The average leakage value of the device in the running state within the lifecycle. Unit is "L/min". |
| RunHrs | ----- | The duration of running time after the device is shipped from factory. This value cannot be cleared. |
| AHI | ----- | Apnea-hypopnea index of the device in the using cycle. Calculation method as Apnea-hypopnea frequency per hour |
| UseDays | ----- | The device is connected to the power supply and continuously running for 4 hours or more it is counted as 1 day. |

9.6 Epworth Interface

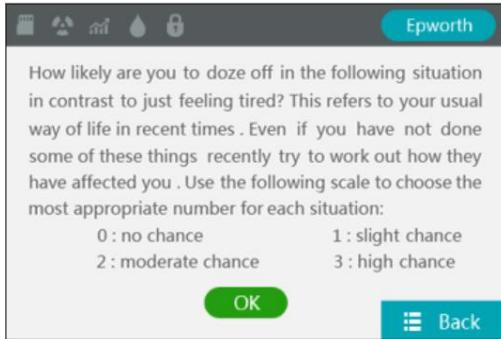

Fig.9.6a : Epworth Interface Screen 1

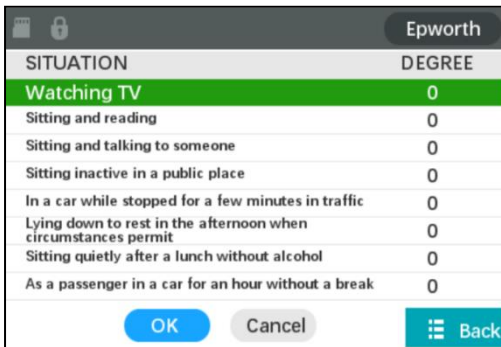

Fig.9.6b : Epworth Interface Screen 2

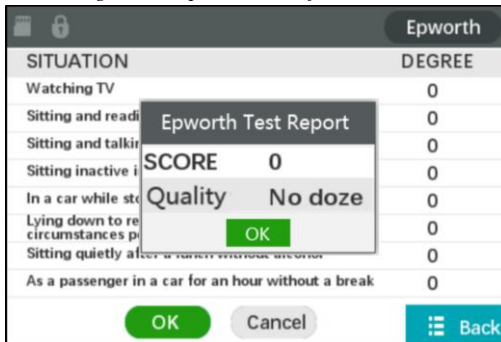

Fig.9.6c : Epworth Interface Screen 3

10. Prompt

| Prompt Message | Description |
|----------------|---|
| Power Failure | If the power supply is disconnected while the device in the Working State , the device will provide a voice prompt via the buzzer for approximately 30 seconds. Pressing the "On/Off " Button or re-powering the device will stop the voice prompts. After power is returned to the device, it will return to the normal state. |
| LOW VOLTAGE!! | When the device detects that the adapter output voltage is below acceptable limits, the device will provide a voice prompt via the buzzer and "LOW VOLTAGE!!" will appear on the display. The warning sounds can be cancelled by pressing the Mute Button. |
| AIRWAY BLOCK!! | When the air flow of the device is blocked, the device will provide a sound prompt via the buzzer, and "AIRWAY BLOCK!!" will appear on the display. The warning sound can be cancelled by pressing the Mute Button. |
| HIGH LEAKAGE!! | When there is a leak in the device's breathing tube, the device will provide a sound prompt via the buzzer and "HIGH LEAKAGE!!" will appear on the display. The warning sound can be cancelled by the Mute Button. |
| HUMI FAILURE! | When the device is connected to the humidifier, the device is powered on, and the humidifier has been heating for 2 minutes, but the humidifier is not working, the device will provide a sound prompt via the buzzer and "HUMI FAILURE!" will appear on the display. The warning sound can be cancelled by pressing the Mute Button. |
| TF CARD FULL! | When the TF card that has been inserted into the device reaches its capacity limit, the device will provide a sound prompt via the buzzer and "TF CARD FULL!" will appear on the display. The audio prompt for this warning is a single tweet, it will only tweet once. |

11. Cleaning, Disinfection and Maintenances

11.1 Timing between Cleanings

Based on hygienic reasons, under normal usage, it is recommended that the operator or user service and / or replace the parts as shown below:

- Clean the device, tube and filter before the device is used for the first time.
- Empty the water tank and clean it daily to prevent bacterial growth.
- Clean the air filter at least once every 2 weeks.
- Replace the air filter with a new filter at least every 3 months.
- Replace the mask with a new one every 3 months.

11.2 Cleaning

11.2.1 Cleaning the host and tubing

To avoid the possibility of electrical shocks and damage to the electrical system, unplug the power cord from the host unit before cleaning the device.

Clean the front panel and the outside of the case with a soft cloth that has been moistened with warm water or mild detergent. Before plugging in the power cord, make sure that the device is completely dry.

△ If the device is used by multiple users, the tubing and mask must be replaced between each use by a different user.

△ When cleaning the tubing and mask, please refer to the Mask User Manual.

11.2.2 Cleaning the water tank

Remove the water tank, open the upper lid, and clean the internal walls of the humidifier unit. Clean and rinse the water tank thoroughly.

Use mild liquid detergent to clean the unit and tank, then rinse with clean water. After cleaning, wipe it clean and allow to dry naturally.

Please ensure that the unit seals tightly after each cleaning.

11.2.3 Clean and Replace the air filter

Clean the air filter thoroughly with warm water and mild detergent, then rinse off all detergent residues thoroughly with clean water. Before reinstalling the air filter, let it air dry completely. If air filter is damaged in any way, please replace it with new filter provided by authorized dealer.

1. Disconnect the device from the power source.
2. Remove the air filter enclosure from the device and remove the air filter.
3. Examine the air filter closely to ensure that it is clean and undamaged.
4. Wash the air filter in warm water with mild detergent as instructed above.
5. Reinstall the air filter

Caution:

△ Never install a wet air filter into the device.

△ Users should alternate between the two air filters included with the device.

This will ensure the air filter has the chance to sufficiently dry after each cleaning and before it is used in the device.

11.3 Disinfection

If you have followed the cleaning instruction correctly, you should not have to sterilize the device or its components. However, if the water tank or any other component is contaminated or if the device is used in a clinic setting, the device should be sterilized with any sanitizer gel available from a pharmacist.

△ Please note that the use of a sanitizing agent will damage the device's surface material and shorten its service life. Therefore, you should follow the sanitizer manufacturer's instruction for the type of material being cleaned.

△ Always use clean water to completely rinse the device components that come into direct contact with the user's skin, including the mask, headgear and tubes. Cleaning the material will help to prevent skin and respiratory tract infection that may be caused by any residual sanitizing solution.

11.4 Transferring to Another User

△ If device is to be used by another user, for sanitation purpose, the device components which come into close contact with this user's skin, such as the mask,

headgear, tube and air filter should be replaced with new ones. Alternatively, users can also follow the procedures listed in Section 11.3 “Disinfection”.

12. Troubleshooting

The below table lists some of the common problems the device might have and provides possible solutions to those problems. If these suggestions do not solve these problems, please contact your healthcare provider directly.

| Phenomenon | Possible Causes | Troubleshooting |
|--|--|--|
| Nothing displays on the screen or the Main Interface screen does not appear after turning the device on. | The power supply is not connected properly. | Disconnect the power plug and re-connect it. |
| The device beeps after turning on. | The power supply is not connected properly. | Disconnect the power plug and re-connect it. |
| The device fails to stop automatically after removing the mask. | “Auto OFF” function is off. | Set the “Auto OFF” function to “ON”. |
| Nose and/or throat are dry and/or irritated when using this device. | The air is dry in the room. | Turn up the humidifier level or consult your doctor. |
| Dry mouth and throat. | Likely because the user sleeps with his or her mouth opened so that the pressurized air goes through the mouth, which leads to dryness of the nasal passages and throat. | The setting pressure may be too low. You may also want to consult your doctor . |
| Eye irritation or dryness. | The model or size of the mask may not be suitable. The mask may also be positioned incorrectly causing air to blow into the user’s eyes. | Adjust the mask position and the headgear’s tightness. Consult your doctor to replace the mask. If the mask is old or broken, replace immediately. Try another mask model. |
| Face reddening or inflamed. | The headgear is too tight. The mask model or size may not be suitable. The user may be allergic to the materials of the mask. | Loosen the headgear and insure proper fit. Consult your doctor. |
| Water in the mask | Room temperature is too low or (if the humidifier is being used) output air can | Lower the humidifier setting, increase the room temperature, or place a |

| | | |
|---|---|--|
| | condense in the tube and collect in the mask. | towel or blanket over the tube to maintain the temperature of the output air flow. |
| Nasal, sinus, or ear pain | Inflammation in sinus or middle ear. | Stop using the device immediately and contact your doctor. |
| Obstructive Sleep Apnea-Hypopnea Syndrome recrudescence (e.g.: daytime sleepiness) | The required treatment pressure may have changed due to your weight, nasal obstruction, drinking or some other reasons. | Consult your doctor. |
| Air output is too hot. | The air filter is either clogged with dirt or the air inlet is otherwise blocked. The device might also be too close to wall, curtains or other obstructions to the air flow around the device. | Check and clean the air inlet, replace if necessary. Reposition the device to a place that is at least 2 inches away from the wall, curtain or other obstructions. |
| No airflow output | Device malfunction | Contact your device supplier. |
| The air flow output is too low | If the “Ramp” function is on, it takes time for air flow to rise from the initial pressure to the treatment pressure. The air inlet may also be blocked. | Turn off or change the settings of the Ramp feature. Check and clean the air inlet or replace the air filter. |
| The blower is always at an abnormally high rotation rate. | The device is leaking air. | Contact your device supplier. |
| The device doesn’t work when it is turned on. | Device malfunction. | Contact your device supplier |
| The device works but the pressure in the mask is obviously different from the setting pressure. | Tubes are either leaking or the device is malfunctioning. | Check to see if the tubing is connected properly. If problem persists, contact your device supplier. |
| The device can only output air at low pressure. | The air filter or air inlet is blocked, or the treatment pressure has been set too low. If the Ramp function is on, it takes time for air flow to rise from the initial pressure to the treatment pressure. | Replace the air filter and clean the air inlet. You may also need to turn off or change the settings of the Ramp feature. |

| | | |
|---------------------------------|--|---|
| The device is excessively loud. | The tube isn't connected properly. The mask or tubing may also be leaking. | Reconnect the tubing and ensure there are no leaks in the tubing. |
| The pressure can't be set. | The Ramp feature is on. | Turn off the Ramp feature, then re-set the pressure. |

⚠ If the problem can't be eliminated immediately by the above suggestions, please contact your device supplier for repair.

⚠ To avoid more injuries or faults, please don't use the device when any of these problems persist.

⚠ Opening this device voids the warranty. Only professionals certified by BEYOND Medical are authorized to open the device.

13. Specifications

Environmental

| | Operating | Storage |
|----------------------|------------------------------|-------------------------------|
| Temperature | 5°C to 35°C (41°F to 95°F) | -20°C to 55°C(-13°F to 158°F) |
| Humidity | 15% to 93% (no condensation) | 15% to 93% (no condensation) |
| Atmospheric Pressure | 700 to 1060 hPa | 700 to 1060 hPa |

Physical

| | |
|------------|--|
| Dimensions | 165mm*200mm*120mm, 280mm*200mm*140mm(with humidifier) |
| Weight | 1.2Kg,2.2Kg (with humidifier) |

Electrical

| | |
|---|--|
| Power adapter | Input: AC100-240V, 50/60Hz, 1.8Amax Output: DC24V, 3.75A |
| Type of protection Against Electric Shock | Class II Equipment |
| Degree of protection Against Electric Shock | Type BF applied part |
| Degree of protection Against Ingress of Water | IP22 |
| Mode of operation | Continuous |
| Applied part | SpO2 Probe, Tubing, Mask |

Noise level

| | |
|------------------------------|--------------|
| Output air flow temperature: | <40°C(104°F) |
|------------------------------|--------------|

The A-weighted sound pressure level does not exceed 30dBA, the A-weighted sound power level does not exceed 38dBA, when the device is working at the pressure of 10 cmH₂O.

Pressure Accuracy

According to the pressure accuracy of ISO 80601-2-70:2015 standard.

Pressure Range:

- CPAP:4 to 20 cmH₂O (in 0.5 cmH₂O increments), ≤ 30 cmH₂O under single fault conditions.

Pressure display accuracy:

± (0.5 cmH₂O +4% of the actual reading)

Pressure stability:

| | |
|------------------------|--------------------------------------|
| Static | Dynamic (4 to 20 cmH ₂ O) |
| ±0.5cmH ₂ O | ≤ 2cmH ₂ O |

Maximum Flow:

According to the maximum flow of ISO 80601-2-70:2015 Standard

CPAP

| | Test pressure (cmH ₂ O) | | | | |
|--|------------------------------------|-----|-----|-----|-----|
| | 4 | 8 | 12 | 16 | 20 |
| Average flow at the user connection port (l/min) | 100 | 120 | 120 | 120 | 120 |

Note: all test data were carried out under conditions with the humidifier and 22mm tube.

Ramp: The ramp time ranges from 0 to 60 minutes.

SpO₂ Range: 0~ 100%.

The margin of error for SpO₂ between 70% and 100% is±3%. No strict accuracy requirements for SpO₂ below 70%.

Pulse Rate

Range: 40~ 240 BPM

Margin of Error: ±3%

Tubing

Length: 1.8m

The Form and the Dimensions of the Patient Connection Port

The 22 mm conical air outlet complies with ISO 5356-1.

Filter

Dimension : 45mm*33mm*10mm

Humidifier

Tested according to EN ISO 8185standard or equivalent methods.

| | |
|---|---|
| Humidity output | Not less than 10mg H ₂ O/L Measured conditions: Max flow, 35°C(95°F), 15% relative humidity. |
| Pressure drop caused by humidifier | < 1cmH ₂ O (with the flow rate of 60 LPM) |
| Leaking under maximum working pressure: | <25mL/min (Together with the tubing) |
| Adaptability | < 20mL/kPa (Together with the tubing) |
| Capacity | 300ml |

Pneumatic Diagram

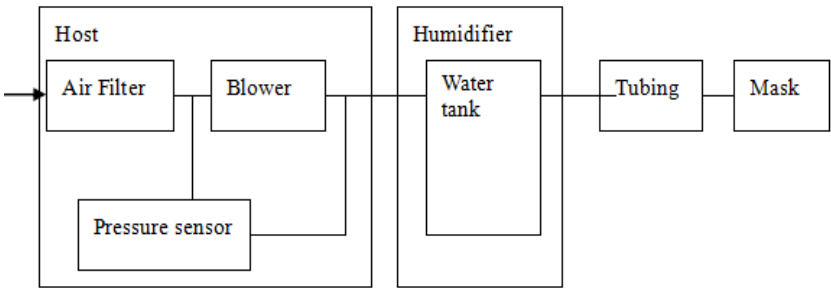

14. Traveling with the Device

1. Only use the BEYOND Medical carrying case when transporting the device and accessories. The device should never be placed in checked baggage.
2. This device operates on power supplies of between 100 - 240 V and 50 / 60 Hz. It can be used in any country in the world, no special adjustments are necessary. However, you will need to find out what type of power sockets are standard in your destination. Power socket adaptors are available separately anywhere you can purchase general electronics.
3. **Security Check Points:** For convenience at security check points, there is a note on the bottom of the device stating that it is medical equipment. It may be helpful to bring this manual along with you to help security personnel better understand the device.

⚠ Empty the water tank of the humidifier and allow it to dry completely before packing the device for your trip. This will prevent any remaining water from entering into the device.

⚠ Be sure to use the device at the proper elevation setting, failure to do so could result in airflow pressures different than the prescribed setting. Always verify both your actual elevation and the device's elevation setting when using the device in a different location.

⚠ If the device is used when the atmospheric pressure is outside of the stated range (See Section 9), the accuracy of the leakage alert will be negatively affected.

15. Service

The device does not require any routine servicing.

△ If you notice any unexplained changes in the performance of the device, if it is making unusual or harsh sounds, if it has been dropped or mishandled, if the enclosure is broken, or if water has entered the enclosure, you must discontinue use and contact your home healthcare provider.

△ If the device malfunctions, contact your home healthcare provider immediately. Never attempt to open the enclosure of the device. Repairs and adjustments must only be performed by service personnel that have been authorized by BEYOND Medical. Unauthorized service could cause injury, invalidate the warranty, and/or result in costly damage.

△ If necessary, contact your local authorized dealer or BEYOND Medical for technical support and documents.

16. Technical Support

Please contact BEYOND Medical directly if you need the circuit diagram of the device or the list of components for certain purposes (such as, maintenance or connection to other equipment). BEYOND Medical will provide the circuit diagram and/or other technical documents in whole or in part according to your needs.

17. Disposal

When the device reaches the end of its service life, please dispose of the device and its packaging in accordance with local laws and regulations.

18. Warranty

From the date of purchase, the manufacturer provides a one-year limited warranty for the host unit and a 3-month limited warranty for the tubing, mask and humidifier.

This limited warranty is only available to the initial consumer. It is not transferable.

For one year (or 3-month) from the original date of purchase, BEYOND Medical will repair or replace any parts of this appliance that prove to be defective in materials or workmanship when such appliance is installed, used and maintained in accordance with the provided instructions.

Exclusions

This warranty does not cover:

1. Product with original serial numbers that have been removed, altered or cannot be readily determined;
2. Any damage caused as a result of improper use, abuse, excessive usage, modification or alteration of the device;
3. Repairs carried out by any service organization that has not been expressly authorized by BEYOND Medical to perform such repairs;
4. Any damage or contamination due to cigarette, pipe, cigar or other smoke;
5. Any damage caused by exposure to ozone, activated oxygen or other gases;
6. Any damage or contamination due to insect infestation; and
7. Any damages caused by external causes such as accidents, fires, or acts of God.

Considering the life of components and safety, medical devices should not be used longer than 5 years. Expired products should be discarded according to corresponding local laws and regulations.

DISCLAIMER OF IMPLIED WARRANTIES; LIMITATION OF REMEDIES

CUSTOMER’S SOLE AND EXCLUSIVE REMEDY UNDER THIS LIMITED WARRANTY SHALL BE PRODUCT REPAIR OR REPLACEMENT AS PROVIDED HEREIN. CLAIMS BASED ON IMPLIED WARRANTIES, INCLUDING WARRANTIES OF MERCHANTABILITY OR FITNESS FOR A PARTICULAR PURPOSE, ARE LIMITED TO ONE YEAR OR THE SHORTEST PERIOD ALLOWED BY LAW, BUT NOT LESS THAN ONE YEAR. BEYOND MEDICAL SHALL NOT BE LIABLE FOR CONSEQUENTIAL OR INCIDENTAL DAMAGES SUCH AS PROPERTY DAMAGE AND INCIDENTAL EXPENSES RESULTING FROM ANY BREACH OF THIS WRITTEN LIMITED WARRANTY OR ANY IMPLIED WARRANTY. SOME STATES DO NOT ALLOW THE EXCLUSION OR LIMITATION OF INCIDENTAL OR CONSEQUENTIAL DAMAGES, OR LIMITATIONS ON THE DURATION OF IMPLIED WARRANTIES, SO THESE LIMITATIONS OR EXCLUSIONS MAY NOT APPLY TO YOU. THIS WRITTEN WARRANTY GIVES YOU SPECIFIC LEGAL RIGHTS. YOU MAY ALSO HAVE OTHER RIGHTS THAT VARY FROM STATE TO STATE.

19. EMC Requirements

Guidance and Manufacturer's Declaration: Electromagnetic Emissions Guidance and Manufacturer's Declaration:

Electromagnetic Emissions

This device is intended for use in the electromagnetic environment specified below. The user of the device should ensure that it is used in such an environment.

| Emissions test | Compliance | Electromagnetic environment-guidance |
|-------------------------|------------|---|
| RF emissions CISPR11 | Group 1 | The device uses RF energy only for its internal function. Therefore, its RF emissions are very low and are not likely to cause any interference in nearby electronic equipment. |
| RF emissions CISPR11 | Class B | This device is suitable for use in all establishments including domestic |

| | | |
|--|----------|---|
| Harmonic emissions IEC61000-3-2 | Class A | establishments and those directly connected to the public low-voltage power supply network that supplies buildings used for domestic purposes |
| Voltage fluctuation /flicker emissions IEC61000-3-3 | Complies | |

Guidance and Manufacturer's Declaration - Electromagnetic Immunity

This device is intended for use in the electromagnetic environment specified below. The user of the device should make sure that it is used in such an environment.

| Immunity test | IEC60601 test level | Compliance level | Electromagnetic environment-guidance |
|--|---|---|---|
| Electrostatic discharge (ESD) IEC61000-4-2 | ±6KV contact ±8KV air | ±6KV contact ±8KV air | Floor should be wood, concrete or ceramic tile. If floors are covered with synthetic material, the relative humidity should be at least 30%. |
| Electrical fast transient /pulse IEC61000-4-4 | ±2KV for power supply lines ±1KV for input/output line | ±2KV for Main power line ±1KV for input/output lines | Mains power quality should be that of a typical home or hospital environment |
| Surge IEC61000-4-5 | ±1K differential mode ±2KV common mode | ±1KV differential mode ±2KV common mode | Mains power quality should be that of a typical home or hospital environment |
| Voltage dips, short interruptions and voltage variations of the input power IEC61000-4-11 | <5% U_T (>95% dip in U_T), for 0.5 cycle 40% U_T (60% dip in U_T), for 5 cycles 70% U_T (30% dip in U_T) for 25 cycles <5% U_T (>95% dip in U_T) for 5 s | <5% U_T (>95% dip in U_T), for 0.5 cycle 40% U_T (60% dip in U_T), for 5 cycles 70% U_T (30% dip in U_T) for 25 cycles <5% U_T (>95% dip in U_T) for 5 s | Mains power quality should be that of a typical commercial or hospital environment. If the user of the device requires continued operation during power mains interruptions, it is recommended that the device be powered from an uninterruptible power supply or from a battery. |

| | | | |
|---|------|------|---|
| Power frequency (50/60Hz) magnetic field IEC61000-4-8 | 3A/m | 3A/m | Power frequency magnetic fields should be at levels characteristic of a typical location in a typical hospital or home environment. |
| <i>Note: U_T is the a.c. mains voltage prior to application of the test level.</i> | | | |

Guidance and Manufacturer's Declaration - Electromagnetic Immunity

This device is intended for use in the electromagnetic environment specified below. The user of the device should make sure that it is used in such an environment.

| Immunity test | IEC60601 test level | Compliance level | Electromagnetic environment-guidance |
|---|---|-------------------|--|
| Conducted RF IEC61000-4-6 Radiated RF IEC61000-4-3 | 3Vrms 150kHz to 80MHz 3V/m 80MHz to 2.5GHz | 3Vrms 3V/m | Portable and mobile RF communications equipment should be used further away from any part of the device (including cables) than the recommended separation distance calculated from the equation applicable to the frequency of the transmitter. Recommended separation distance $d = 1.2\sqrt{P}$ $d = 1.2\sqrt{P}$ 80MHz to 800MHz $d = 2.3\sqrt{P}$ 800MHz to 2.5GHz \sqrt{P} is the maximum normal output power of the transmitter, its unit is Watt (W) and d is the recommended separation distance, its unit is meter (m). Measured magnetic field strengths from a fixed RF transmitter should be less than the compliance level in each frequency range b. Interference may occur in the vicinity of equipment marked with the following symbol:  |
| <p><i>Note 1: At 80 MHz and 800 MHz, the higher frequency range applied.</i></p> <p><i>Note 2: These guidelines may not apply in all situations. Electromagnetic propagation is affected by absorption and reflection of the structures, objects and people.</i></p> <p>a. <i>Field strengths from fixed transmitters, such as base stations for radio (cellular / cordless) telephones and land mobile radios, amateur radio, AM and FM radio broadcast and TV broadcast cannot be predicted theoretically with accuracy. To assess the electromagnetic environment due to fixed RF transmitters, an electromagnetic site survey should be</i></p> | | | |

considered. If the measured field strength in the location in which the device is used exceeds the applicable RF compliance level above, the device should be observed to verify normal operation. If abnormal performance is observed, additional measures may be necessary, such as re-orienting or relocating the device.

- b. Over the frequency range 150 kHz to 80 MHz, the field strengths should be less than 3 V/m.

Recommended separation distances between portable and mobile RF communications equipment and the device:

The device is intended for use in an electromagnetic environment in which radiated RF disturbances are controlled. The customer or the user of the device can help prevent electromagnetic interference by maintaining a minimum distance between portable and mobile RF communications equipment (transmitters) and the device as recommended below, according to the maximum output power of the communications equipment.

| Rated maximum output of transmitter (W) | Separation Distances According to Frequency of Transmitter | | |
|---|--|---------------------------------------|--|
| | 150 kHz ~ 80 MHz $d = 1.2\sqrt{P}$ | 80 MHz ~ 800 MHz $d = 1.2\sqrt{P}$ | 800 MHz ~ 2.5 GHz $d = 2.3\sqrt{P}$ |
| 0.01 | 0.12 | 0.12 | 0.23 |
| 0.1 | 0.38 | 0.38 | 0.73 |
| 1 | 1.2 | 1.2 | 2.3 |
| 10 | 3.8 | 3.8 | 7.3 |
| 100 | 12 | 12 | 23 |

For transmitters rated at a maximum output power not listed above, the recommended separation distance (d) in meters(m) can be estimated using the equation applicable to the frequency of the transmitter, where P is the maximum output power rating of the transmitter in watts(W) according to the transmitter manufacturer.

Note 1: At 80 MHz and 800 MHz, the higher frequency range applied.

Note 2: These guidelines may not apply in all situations. Electromagnetic propagation is affected by absorption and reflection of the structures, objects and people.

Manufacturer:

Hunan Beyond Medical Technology Co.,Ltd.

**Address: BEYOND ZONE, LIJIACUN RD,
XUESHI STREET, CHANGSHA, HUNAN 410208,
CHINA.ina.**

Contact Number: +86-731-82564299

www.csbeyond.com

U.S Agent:

United Source LLC

Email: BEYOND@united-source.com

**Address: 1521 Concord Pike, Suite 301, Wilmington,
DE, 19803, USA**

VersionNo.: U.S./20201218/A1